



EVC100X Optical warning Xenon Flash

Protection mode:

Type of protection: II 2 G EEx d IIC
 Class of temperature: T3
 Protection degree: IP65
 Ambient Temp : -20 à +40°C
 Zones :
 Certificate: INERIS 03 ATEX 0197X



Description:

The EVC100/X fixture is composed of a central body on which a box with fixing flange is mounted, complete with tempered glass globe, containing a blinking lamp Xenoflash. To complete the code, please add the figure showing the color. (Example: EVC100X.RO)
 For optical warning of alarms, damages, etc...

Technical data:

Materials:

Body: aluminium alloy.
 Globe: tempered glass.

Cables entries:

2 entries. 3/4 UNI 6125

On request:

Stainless steel protection guard.
 Others types of connections on the fixtures.

Technical drawing:

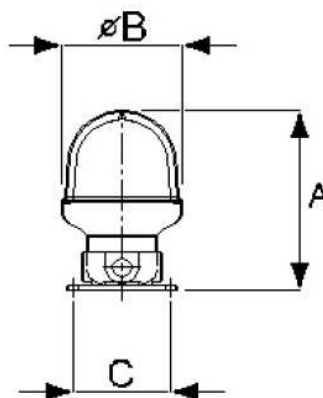

Type	Dimensions (mm)			Voltage (V)		Power	Available colours	Working
	A	B	C	(Vdc)	(Vac)			
EVC 100 / X...	194	134	108	12 / 24 48	12 / 24 48 110 220 / 240	25 W	BL=Blue GI=Yellow NT=Neutral RO=Red VE=Green	ON ••